

Booth Layout Guidelines

Linear Booth

Linear Booths have only one side exposed to an aisle and are generally arranged in a series along a straight line. They are also called “in-line” booths.

Dimensions

To maintain consistency and for ease of layout and/or reconfiguration, floor plan design in increments of 10 ft. (3.05m) has become the standard in the United States. Therefore, Linear Booths are most commonly ten feet (3.05m) wide and ten feet (3.05m) deep (10'x10').

Maximum backwall height limit: 8 ft. (2.5m)

Use of Space

Regardless of the number of Linear Booths utilized, display materials should be arranged in such a manner so as not to obstruct sight lines of neighboring exhibitors. The maximum height of 8 ft. (2.44m) is allowed only in the rear half of the booth space, with a 3 ft (0.91m) height restriction imposed on all materials in the remaining space forward to the aisle.

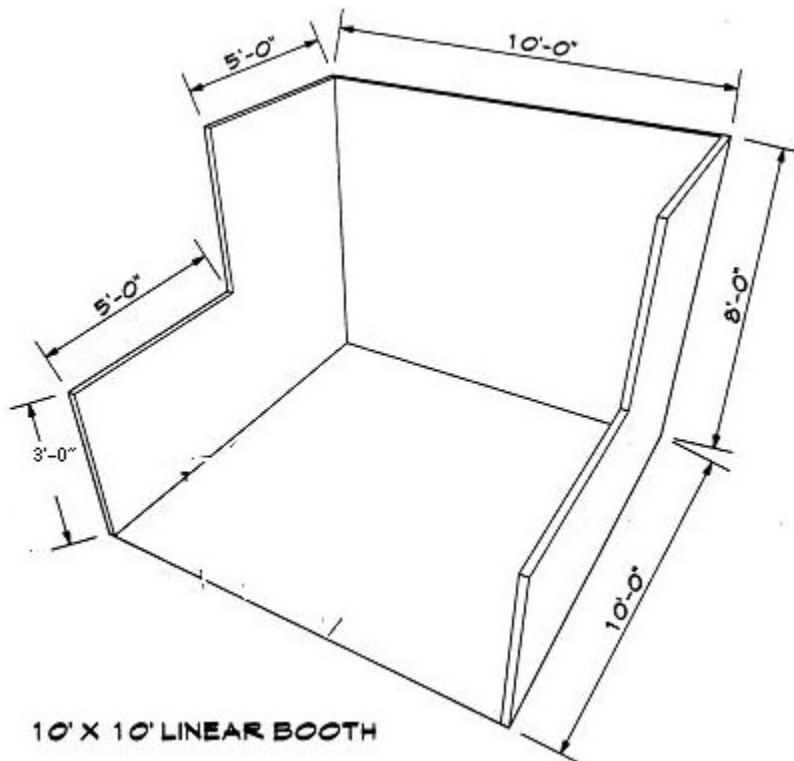

Corner Booth

A Corner Booth is a Linear Booth exposed to aisles on two sides. All other guidelines for Linear Booths apply.

Perimeter Booth

A Perimeter Booth is simply a Linear Booth that backs to a wall of the exhibit facility rather than to another exhibit.

Dimensions and Use of Space

All guidelines for Linear Booths apply to Perimeter Booths except that the typical maximum backwall height is twelve feet (3.66m).

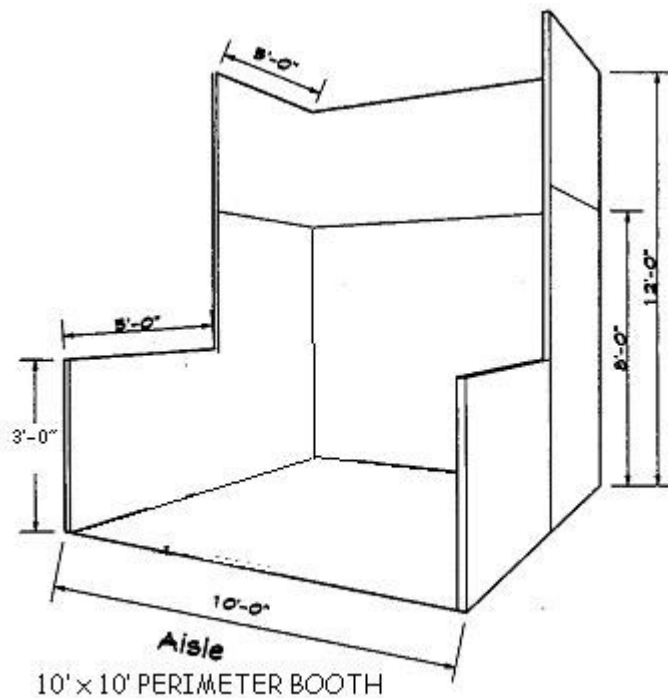

Peninsula Booth

A Peninsula Booth is exposed to aisles on three (3) sides and composed of a minimum of four booths. There are two types of Peninsula Booths: (a) one which backs up to Linear Booths, and (b) one which backs to another Peninsula Booth and is referred to as a "Split Island Booth."

Dimensions

A Peninsula Booth is usually 20'x20' (6.1m x 6.1m) or larger. When a Peninsula Booth backs up to two Linear Booths, the backwall is restricted to 3' (0.91m) high within 5' (1.52m) of each aisle, permitting adequate line of sight for the adjoining Linear Booths. Overhead hanging signs or banners up to 16' (4.88m) may be permissible with show management approval.

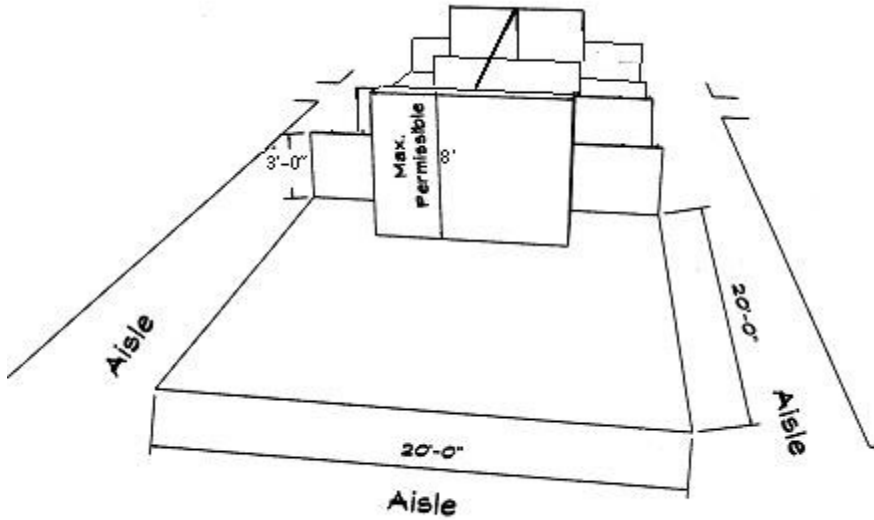

Split Island Booth

A split Island Booth is a Peninsula Booth which shares a common backwall with another Peninsula Booth. The entire cubic content of this booth may be used, up to the maximum allowable height, without any back wall line of sight restrictions. Sixteen feet (4.88m) is a typical maximum height allowance, including signage. The entire cubic content of the space may be used up to the maximum allowable height.

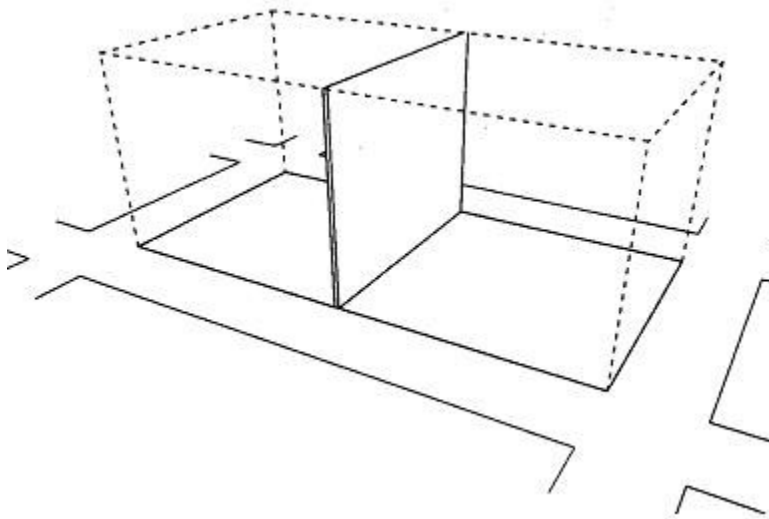

Island Booth

An Island Booth is any size booth exposed to aisles on all four sides.

Dimensions

An Island Booth is typically 20'x20' (7.75m x 7.75m) or larger, although it may be configured differently.

Use of Space

The entire cubic content of the space may be used up to the maximum allowable height, which is usually 16' (4.88m), including signage.

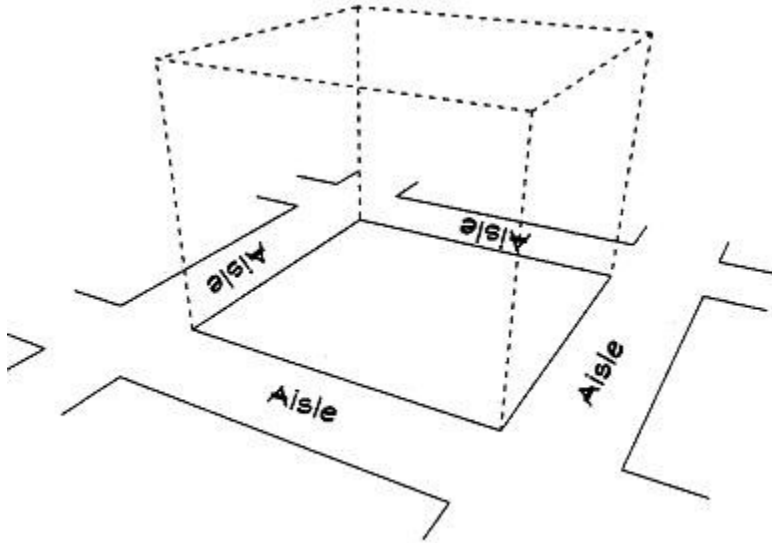

Other Important Considerations

Canopies and Ceilings

Canopies, including ceilings, umbrellas and canopy frames, can be either decorative or functional (such as to shade computer monitors from ambient light or for hanging products). Canopies for Linear or Perimeter Booths should comply with line of sight requirements (see “Use of Space for Linear or Perimeter Booths”).

The base of the Canopy should not be lower than 7’ (2.13m) from the floor within 5’ (1.52m) of any aisle. Canopy supports should be no wider than three inches (3”). This applies to any booth configuration that has a sightline restriction, such as a Linear Booth. Fire and safety regulations in many facilities strictly govern the use of canopies, ceilings and other similar coverings. Check with the appropriate local agencies prior to determining specific exhibition rules.

Hanging Signs & Graphics

Hanging signs and graphics may be permitted in Peninsula and Island Booths with show management approval, usually to a maximum height of 16’ (4.88m). Whether suspended from above or supported from below, they should comply with all ordinary use-of-space requirements (for example, the highest point of any sign should not exceed the maximum allowable height for the booth type).

Hanging Signs & Graphics should be set back 10’ (3.05m) from adjacent booths.

Approval for the use of Hanging Signs & Graphics should be received from Show Management at least 60 days prior to installation. Drawings must be available for

inspection.

Towers

A Tower is a freestanding exhibit component separate from the main exhibit fixture. The height restriction is the same as that which applies to the appropriate exhibit configuration being used.

Towers in excess of 8' (2.44m) must have drawings available for inspection and have show management approval. Fire and safety regulations in many facilities strictly govern the use of towers. A building permit may be required.

Multi-story Exhibit

A Multi-story Exhibit is a booth where the display fixtures exceed 12' (3.66m), including Double-decker and Triple-decker Booths. In many cities, a Multi-storied Exhibit requires prior approval by the exhibit facility and/or relevant local government agency because it is deemed to be a "structure" for building purposes. The city building department generally needs to issue a building permit based on an application and drawings prepared and submitted by a licensed architect or engineer. Exhibitors should obtain local building regulations early on to ensure that all time constraints are met.

